

MAKE THE UPTON SKIRT

Hack the Upton Dress



JENNY RUSHMORE

UPTON SKIRT

HACK THE UPTON DRESS

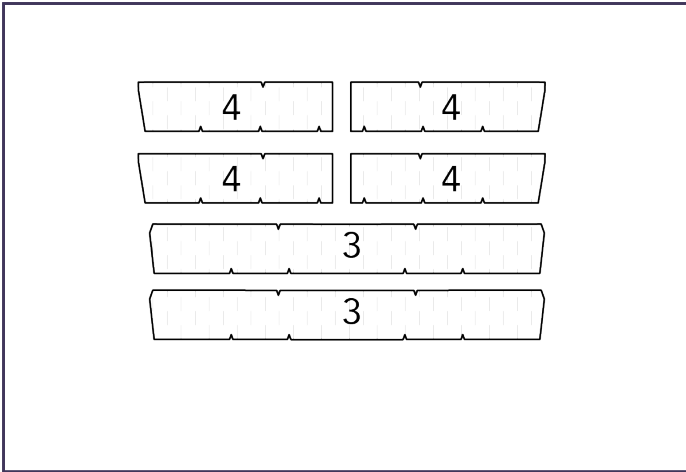

STEP ONE:

Cut 2 front skirts, 2 back skirts, 2 front waistbands and 4 back waistbands, and 4 pockets, if desired. Interface waistband pieces. You will also need a zipper to make the skirt, approximately 9" long.

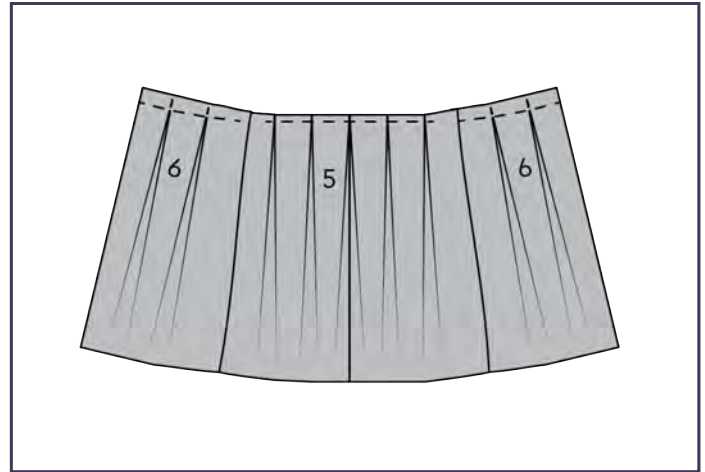

STEP TWO:

Follow Upton Dress instructions for constructing the skirt (steps 1 - 4), pockets (if wanted), and side seams (steps 1 - 4). Note, these instructions will work for either skirt view (pleated or gored).

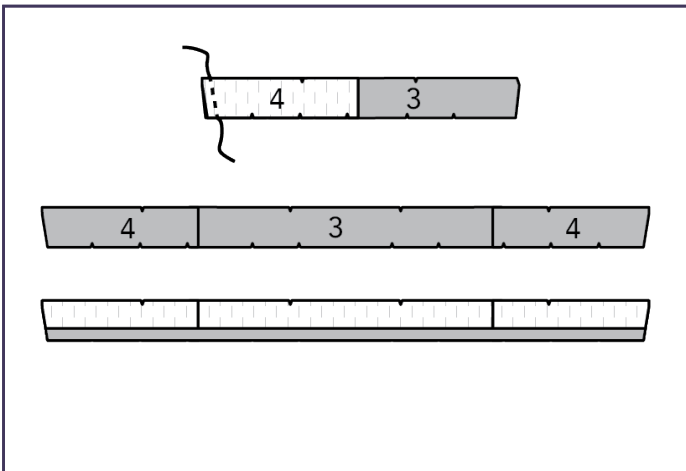

STEP THREE:

Sew one back waistband to end of one front waistband. Sew second back waistband to other end of front waistband. Press. Repeat to make a second long waistband: this will be the facing. On the facing, fold up long bottom edge 1/2" (12mm) to wrong side, press.

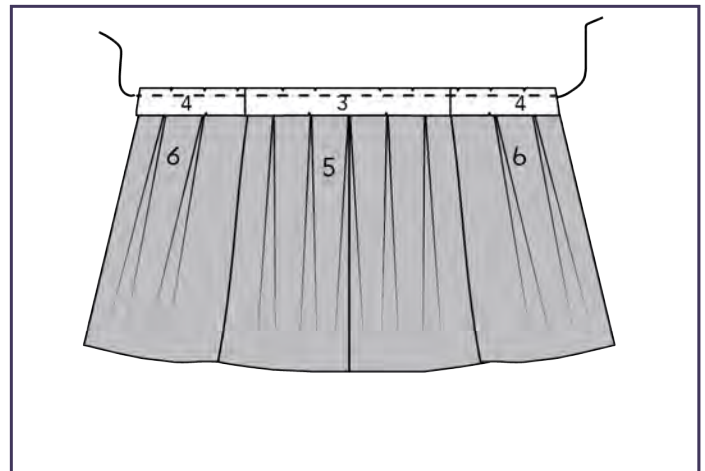

STEP FOUR:

Pin waistband to skirt, matching side seams and notches. Sew at 1/2" (12mm) seam allowance.

UPTON SKIRT

HACK THE UPTON DRESS

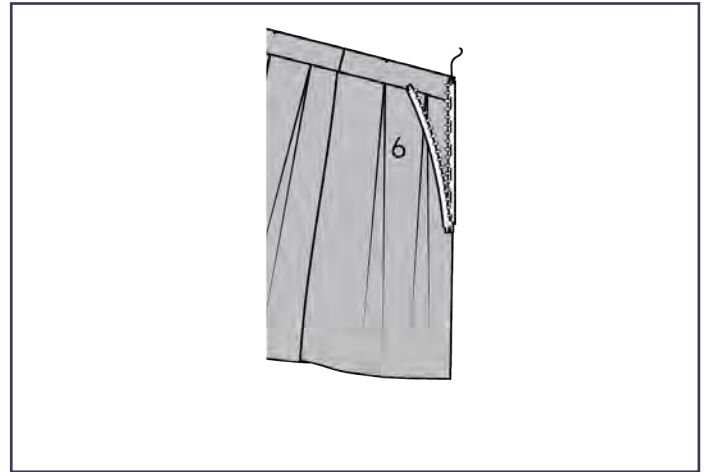
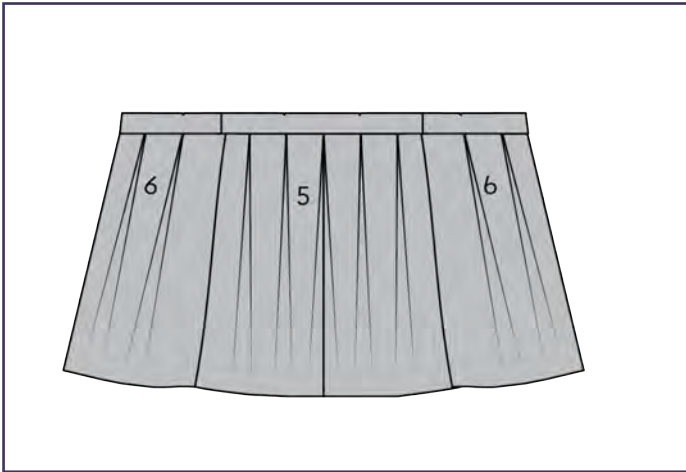

STEP FIVE:

Press waistband up, and press seam allowance up towards waistband. Finish the seam allowances of the two open edges of the center back, from top of waistband to hem.

STEP SIX:

Optional: open zip and gently press zip teeth away from tape using a warm (not hot) iron.

Place open zip on skirt back opening with right sides together, as shown. Top zip teeth should be $\frac{1}{2}$ " (12mm) from the top of the skirt, and the zip teeth facing left. Pin and sew zip to skirt back using a zip or invisible zip foot. Sew close to the teeth, starting at the top and going as far down the zip as possible.

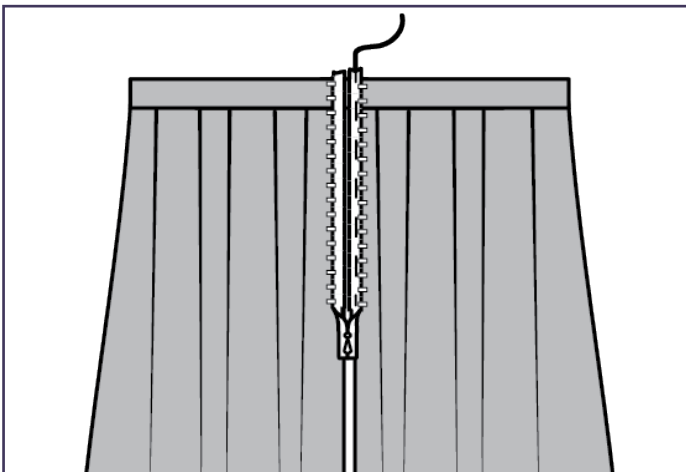

STEP SEVEN:

Flip zip over, and secure right hand side of zip to right hand side back of skirt, using pins, wonder tape, or glue. Test if it zips up correctly, ensuring bottom of zip pull looks as shown. Sew second side of zip to skirt.

UPTON SKIRT

HACK THE UPTON DRESS

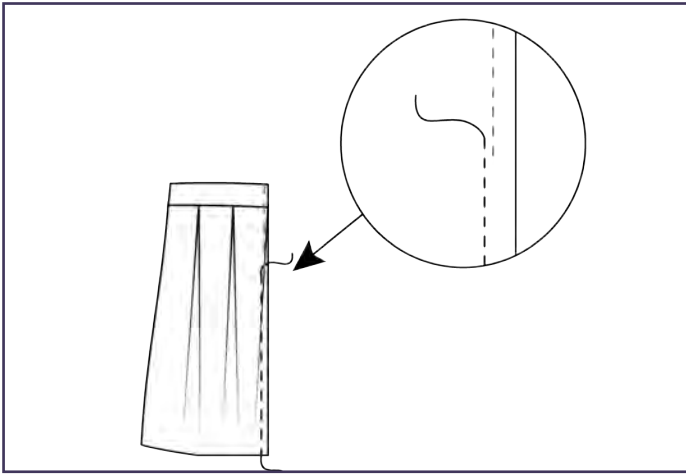

STEP EIGHT:

Pin back pieces from bottom of zip to hem, with right sides together and zip closed. Sew seam, starting just above and to the left of where zip stitching ends. Press seam allowances open.

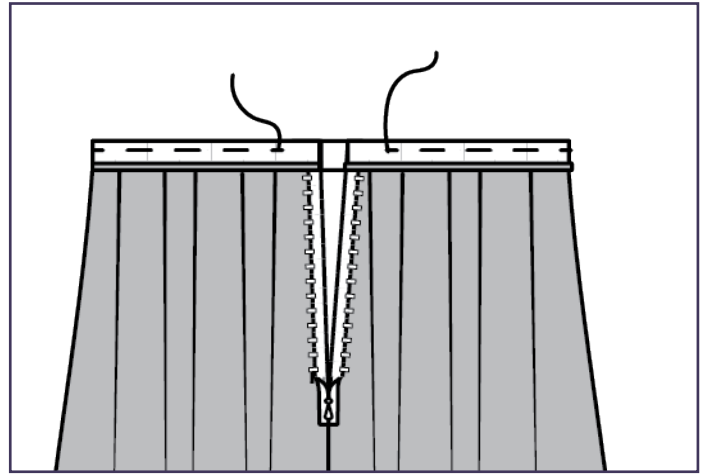

STEP NINE:

Pin facing to waistband, right sides together. Sew around waistline, stopping 1" from zip at each end.

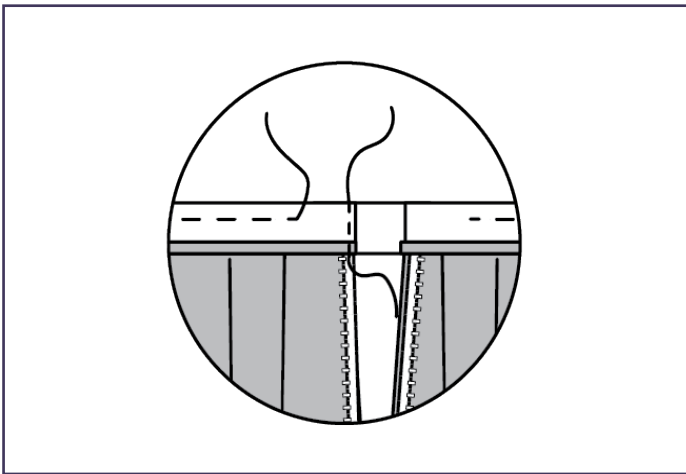

STEP TEN:

Pin end of facing on top of the zip, so the zip is sandwiched between the facing and waistband. Sew facing to zipper tape, sewing close to zip teeth and using a zipper foot.

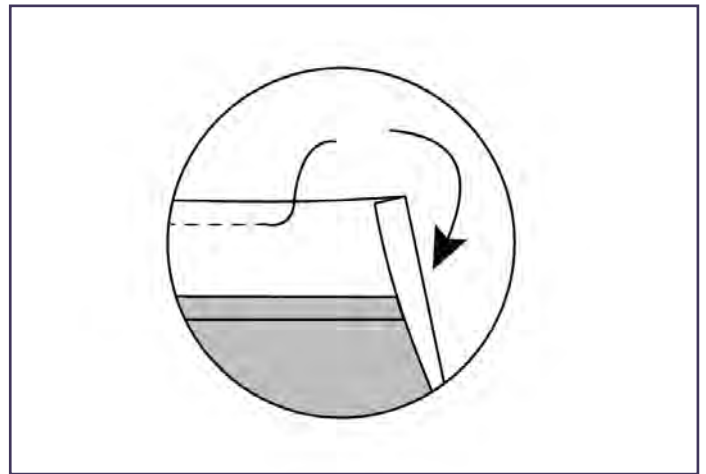

STEP ELEVEN:

At top of zip, fold skirt over to right side, so you can feel zip teeth in the edge of the fold. Pin.

UPTON SKIRT

HACK THE UPTON DRESS

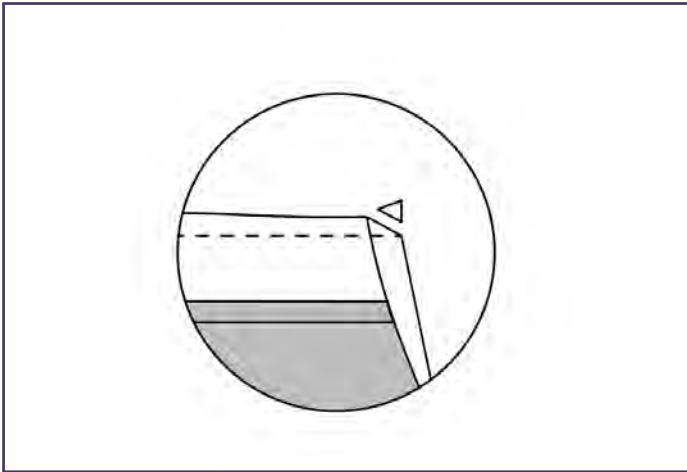

STEP TWELVE:

Sew remaining inch of facing to waistband, sewing across fold at top of zip. Trim corner.

Repeat with second end of waistband.

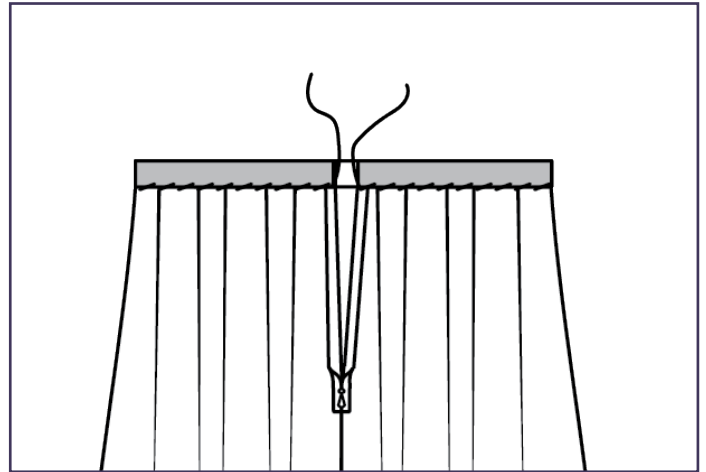

STEP THIRTEEN:

Flip facing to inside of skirt. Carefully turn out the corners with a point turner. Press. Slipstitch facing to waistband seam allowance using a hand needle, or stitch in the ditch from the right side.

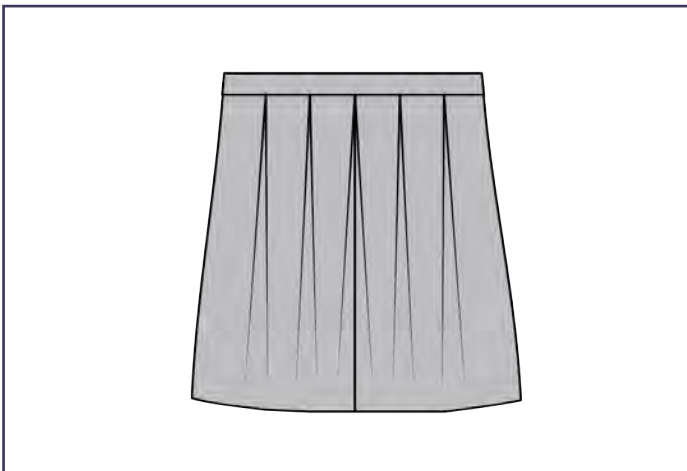

STEP FOURTEEN:

Hem your skirt.

And you're done!